

ONHM **Narrow Multi-Deck Merchandiser** 4', 6', 8' & 12' (Deli / Meat)

ELECTRICAL DATA

Case Length	Fans Per Case	High Efficiency Fans		Defrost Heaters			
		120 Volts		208 Volts		240 Volts	
		Amps	Watts	Amps	Watts	Amps	Watts
4'	2	0.47	28.0	1.92	400	2.22	532
6'	3	0.70	42.0	2.88	600	3.33	798
8'	4	0.93	56.0	3.85	800	4.44	1065
12'	5	1.17	70.0	5.77	1200	6.67	1600

LIGHTING DATA

Case Length	Lights Per Row	Light Length	Clearvoyant LED Lighting (Per Light Row)			
			Standard Power (Cornice or Shelf)		High Power (Cornice)	
			120 Volts		120 Volts	
			Amps	Watts	Amps	Watts
4'	1	4'	0.10	11.9	0.18	21.5
6'	2	3'	0.14	16.6	0.25	29.8
8'	2	4'	0.20	23.8	0.36	43.0
12'	3	4'	0.30	35.7	0.54	64.5

GUIDELINES and CONTROL SETTINGS

Front/Rear Sill Heights	BTUH/ft		Superheat Set Point @ Bulb (°F)	Evaporator (°F)	Discharge Air (°F)	Discharge Air Velocity (FPM)
	Conventional	Parallel				
Standard	1462	1320	6 - 8	22	30	340
All Others	1351	1220	6 - 8	22	30	340

DEFROST CONTROLS

Defrosts Per Day	Run-Off Time (Min)	Electric Defrost		Timed-Off Defrost		Hot Gas Defrost	
		Fail-Safe (Min)	Termination Temp (°F)	Fail-Safe (Min)	Termination Temp (°F)	Fail-Safe (Min)	Termination Temp (°F)
4	6 - 8	35	47	45	47	26	45

NOTES:

- Extended front sills are required on meat applications to maintain proper product temperature. An extended front has a minimum height of 24" on a 5" baseframe, or 30" on an 11" baseframe.
- BTUH/ft notes:
 - Listed BTUH/ft data represent unlighted shelves. For LED lighting, add 9 BTUH/ft per row of lighted shelving. For T8 lighted shelves, see Hillphoenix Bluebook Appendix D for BTUH, amp and watt data.
- Listed discharge air velocity represents the average velocity at the peak of defrost.
- Temperature and defrost settings listed above are recommended start-up settings. Final operational settings may need to be adjusted for the store conditions in which the case operates.
- The recommended evaporator temperatures may need to be adjusted based on system setup, store conditions, etc. The minimum recommended evaporator temperature is 4°F below the listed evaporator temperature.

Hillphoenix

REVISION: 120501_0000

DOVER COMPANY



All measurements are taken per ASHRAE - 72 - 2005 specifications. Hillphoenix refrigerated display cases for sale in the United States meet or exceed Department of Energy 2012 energy efficiency requirements.

Defrost Schedule	
Defrosts per Day	Time
1	12 midnight
2	12am - 12pm
3	6am - 2pm - 10pm
4	12am-6am-12pm-6pm
6	12am-4am-8am-12pm-4pm-8pm

ONHM Narrow Multi-Deck Merchandiser

4', 6', 8' & 12' (Deli / Meat)

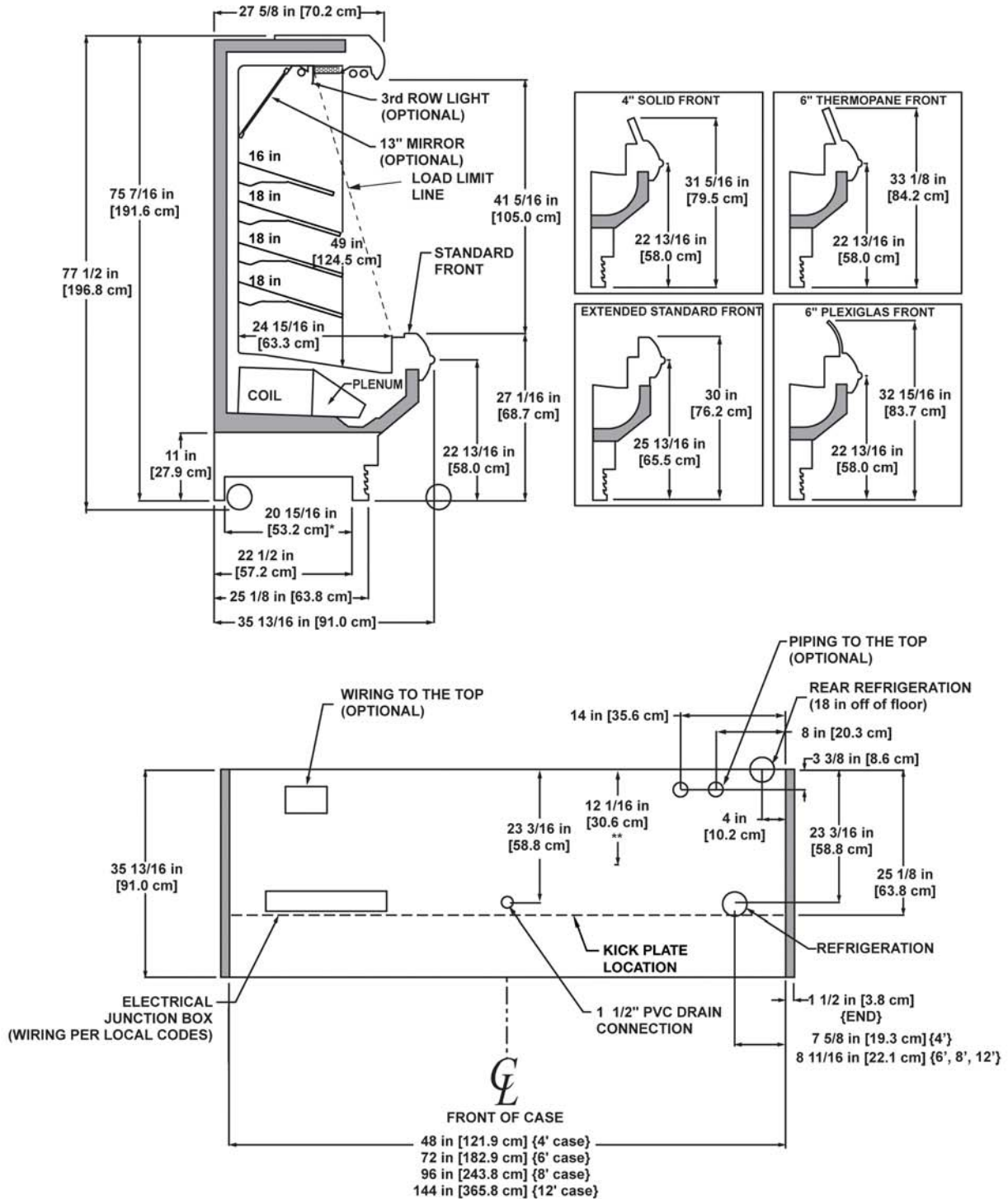

NOTES:

* STUB-UP AREA

** RECOMMENDED STUB-UP CENTERLINE FOR ELECTRICAL AND HUB DRAINS

- FRONT SILL HEIGHT AND OVERALL CASE HEIGHT VARY WITH BASEFRAME HEIGHT
- ENDS ADD APPROXIMATELY 1 INCH TO CASE HEIGHT
- WIRING-TO-THE-TOP ADDS APPROXIMATELY 4 INCHES TO CASE HEIGHT
- A 2" MINIMUM AIR GAP IS REQUIRED BETWEEN THE REAR OF THE CASE AND A WALL
- AVAILABLE SHELF SIZES: 10", 12", 14", 16", 18" & 20"
- RECOMMENDED SHELF CONFIGURATION IN ROWS: 1-12", 1-14", 1-16" & 1-18"
- DASHED LINES SIGNIFY AREA INSIDE BASE RAIL BEHIND KICK-PLATE

